

ORANKA.

The patented beverage system.



With the new ORANKA beverage system, you are opting for innovative design, healthy, fruity branded products and a modern generation of patented and extremely energy-efficient drink dispensers of the highest technical standard.

The packaging size of the concentrates, the container volume, the cooling capacity and the mixing proportions are perfectly attuned to one another with ORANKA brand products. You can also choose between various options to enhance your system. You will then be able to provide your customers or guests with delicious cold drinks around the clock.

ORANKA. Fruity, refreshing and healthy.



WJGmbH-PP002-2-2311020-EN

ORANKA on the internet

Find out more about our wide range of drinks at www.oranka.com. Whether you are looking for new, innovative products or detailed information about our numerous awards and certifications – it's worth taking a look at our homepage.

ORANKA. We are here to help.



The ORANKA brand has a tradition stretching back many decades. As a specialist in drinks supply and the production of fruit juice and refreshing drink concentrates, the highest product quality has always been our aim. Numerous product awards and various patents testify to our efforts to achieve perfection. Make the most of our customised drinks concept for your individual requirements.

ORANKA. Brand quality in a beverage system.

PREMIUM QUALITY
MADE IN GERMANY



NEW
with LED lighting



ORANKA
Wolfgang Jobmann GmbH
Gutenbergstraße 10
D-21465 Reinbek

Central Sales Germany:
Phone +49 (0)40 722 3026
Fax +49 (0)40 722 9559
sales@oranka.de

Service:
Phone +49 (0)40 722 3026
service@oranka.de

www.oranka.com

**EXCLUSIVE
OFFER
FOR NEW
CUSTOMERS!**

ORANKA Exclusive⁺.
The new beverage system with LED lighting.

The patented ORANKA beverage system.

With the new ORANKA beverage system, you are opting for innovative design and a timeless modern generation of drink dispensers at the highest technical level.

Numerous patents, continuous development and various hygiene certificates and recommendations in accordance with HACCP ensure even more product safety and underline our quality standards.

Easy handling without tying up personnel is a matter of course.

Container volume, mixing ratio and packaging size are in perfect harmony. So you can treat your customers or guests to delicious chilled drinks around the clock. Our secure cooling system, in combination with the ORANKA Aroma-Safe cover and our ORANKA Aroma-Cap, ensures airtight sealing and maximum freshness.

The fact that you can see the drink and the attractive illumination of the transparent container encourages people to try a glass. Our fruit drinks are therefore a welcome and healthy pleasure for everyday consumption.

Recommended by experts

It is no accident that, after extensive testing, the BVLK - the Bundesverband der Lebensmittelkontrolleure Deutschlands (German Federal Association of Food Inspectors) - recommends our dispensers.



Of course, with the new ORANKA dispenser you have everything covered when it comes to hygiene.

As required by the Food Hygiene Regulations and DIN standards 10501-2 and 10519, the protective devices of the patented ORANKA dispenser do an outstanding job in preventing any adverse effects on the drinks.

With its high performance capacity, the ORANKA dispenser also meets the hygiene regulations for perishable foods without preservatives. Fast refrigeration extends the shelf life of the drink.

- The ORANKA container lid can be locked. This provides protection against unauthorised access.
- As an option, dispensing of drinks can also be locked outside operating hours.
- The refrigeration effect is achieved via the stainless steel base with assured hygiene in accordance with HACCP.
- The top section can be removed when full, as it is a sealed and secure system.
- All parts can be hygienically cleaned in the dishwasher.
- Of course, the ORANKA dispenser also comes with a hygiene certificate, hygiene information and operating instructions.

ORANKA Hygienic Design

The ORANKA Hygienic Design and the high-quality, perfectly attuned materials used in it offer you numerous advantages:

Thanks to the patented **magnetic lock** in the lid, the container is protected easily and safely against unauthorised access.

With the **ORANKA Aroma-Cap**, retains the delicious flavour and valuable vitamin C in the healthy ORANKA branded beverages are preserved for as long as possible.

The **mixer** is easy to fit to the axis in the container and is operated magnetically.

Thanks to the patented **sealed stainless steel base**, you can even remove the container when full.

The moist felt ring prevents the container from freezing to the cooling unit and ensures **even and very fast cooling**.

The strong, friction-fitted **container lock** is easy to use and provides stability and safety.

The fan motor and safety air slits prevent **any build-up of heat** and the machine is **protected** from penetrating moisture.

Certified safety

It goes without saying that all ORANKA dispensers are strictly tested in accordance with the GS and VDE standards and have an electric cable with strain relief.

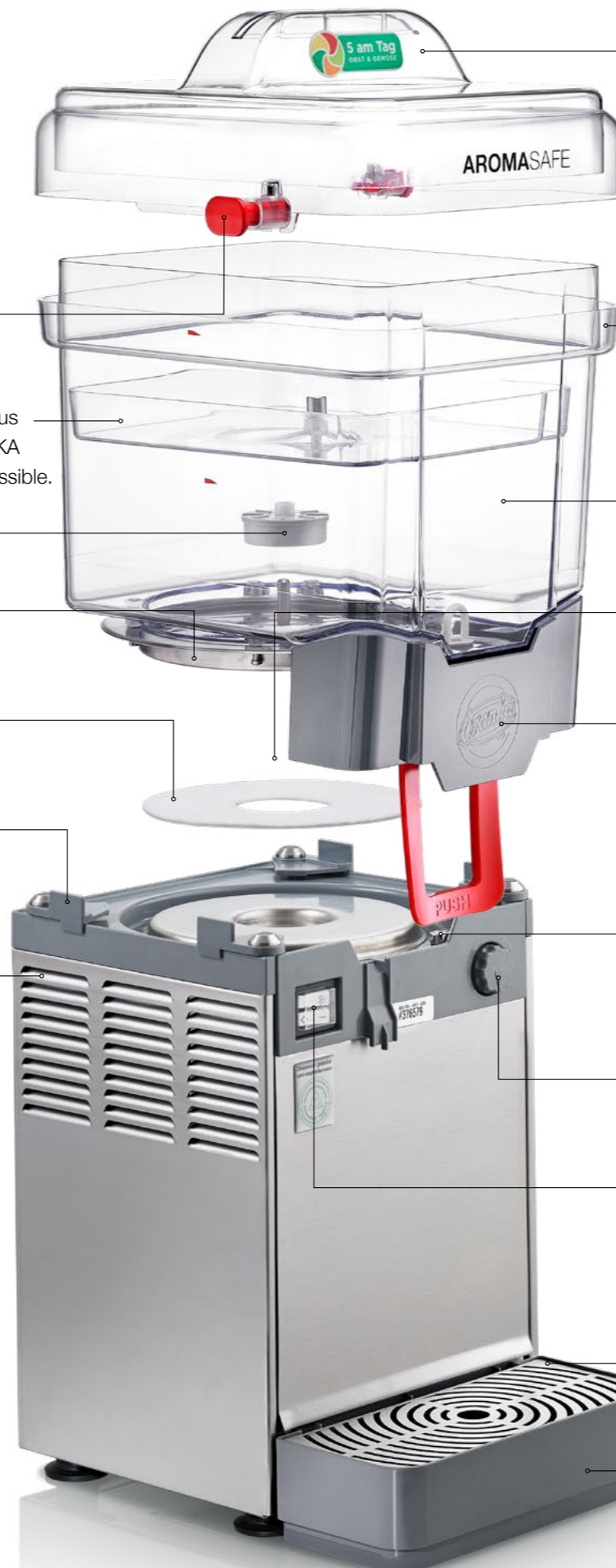

There is a **holder** in the lid for ORANKA product cards. Detailed information about the ingredients in our fruity branded beverages can therefore be provided easily **in accordance with the FIR**.

The liquid seal between the ORANKA container and the lid means that the system can be sealed so that it is **virtually 100 % airtight**. You can therefore enjoy the highest quality and **maximum product freshness**.

The **fact that you can see the beverage** underlines its freshness and encourages people to enjoy a glass of the product.

Thanks to the **patented refrigeration technology**, the dispenser works with **high energy efficiency** and cools the drink down quickly.

Like all the other system parts, the **new dispenser unit** is easy to disassemble and clean. The **modern design** also protects the on/off switch and the temperature control system against unauthorised access.

With the integrated, energy-efficient **LED lighting**, which can be operated separately if required, the fruit drink in the container can be illuminated in an **extremely appealing and colourful way**.

Thanks to the high-quality, continuously adjustable thermostat, the drinks are always **at the perfect temperature** – as set by you in advance.

The strong stainless steel cooling unit is easy to use. The **double safety switches (on/off)** for the cooling and the LED lighting and temperature controller are easily accessible on the front.

The **high-quality stainless steel grate** underlines the **premium quality** of the patented ORANKA beverage system.

With the **drip tray** fitted to it, the surrounding area also stays clean.

You can choose between a **10-litre** and a **20-litre container** to suit your needs. Whichever you choose: optimal cooling is a matter of course. And the rectangular design ensures easy handling.

ORANKA. How practical.

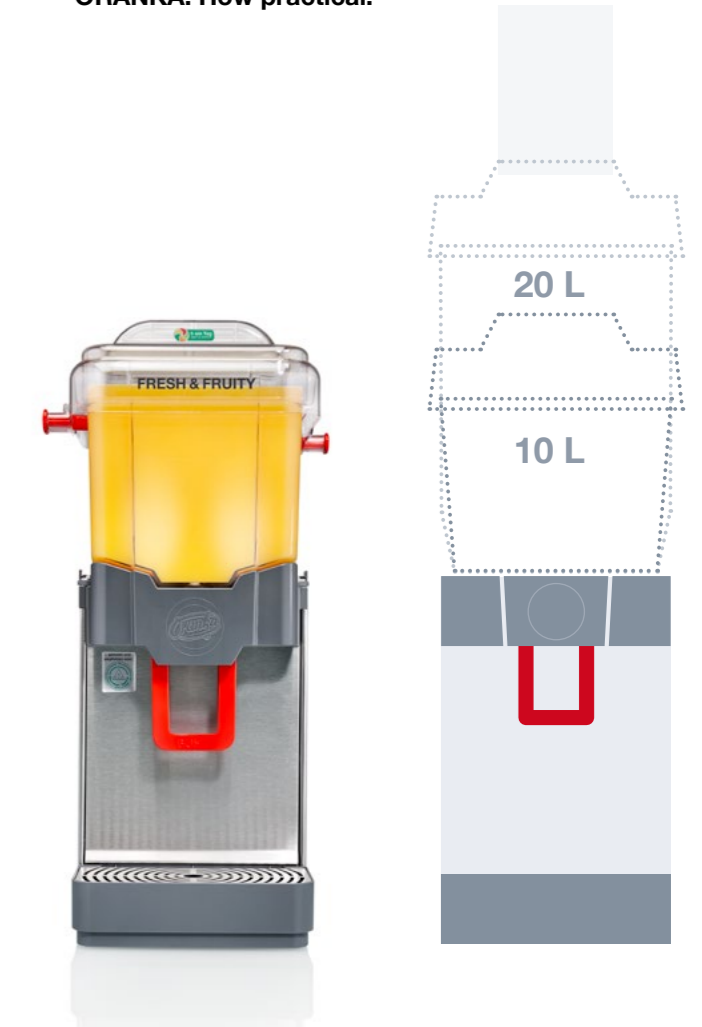

Technical data

Cooling unit

- Cooling capacity: 240 watts (maximum value)
- Average active power consumption: approx. 20.7 watts
- Connected electrical loads: 230 V ~ 50 Hz
- Low power consumption thanks to thermostatic switch (the average consumption in everyday use is in the range of an energy-saving lightbulb)
- Empty weight of machine: approx. 15.9 kg

Dimensions (WxHxD)

10-litre capacity	20-litre capacity
Width: 30.0 cm	Width: 30.0 cm
Height: 63.0 cm	Height: 80.5 cm
Depth: 34.5 cm	Depth: 34.5 cm